

To turn pages go to the bottom of page and left click with the mouse on the arrow or use the left and right arrow keys on the keyboard.



NITE Systems

Catalog Contents

NITE Systems	1
NITE Phoenix System.....	1
NITE Plus System.....	4
NITE Battery Specifications.....	6
NITE Day Cab System.....	7
Index	8

The NITE Phoenix is the ultimate in battery-powered electric air conditioning systems. It is designed to keep sleeper compartments cool in even the hottest climates without idling the engine. Automatic temperature control assists in keeping the sleeper compartment at a comfortable temperature year round. NITE Phoenix is available in A/C only as well as a combo configuration that provides both cooling and heating capabilities. Optional heating systems will require small amounts of diesel usage.

The NITE Phoenix requires four additional auxiliary batteries that meet the following criteria: AGM (Absorbed Glass Mat), deep cycle group 27 or 31. Use of any non-approved battery technology will automatically void any warranty and may impede the performance of the NITE system. Lithium Ion battery technology is being developed for the Phoenix unit.

Please see www.nitesystems.com for updates.

To obtain information about any of the NITE systems go to www.nitesystem.com or call toll free 1-866-204-8570

CARB approved [# 08-643-004]



NITE A/C System with Digital Controller

- Cooling Capacity - 7500 BTU/h
- Voltage - 12 Volts D.C.
- Weight - 70 lbs.
- Unit Dimensions - 22.0" L x 17.0" W x 11.0" H
- Sealed hermetic system - eliminates refrigerant leaks
- Variable speed compressor - for greater efficiency
- All 12VDC components - requires no power inverter
- Brushless DC (BLDC) technology
- Patented technology

Digital Controller

- LCD Digital Display
- Auto Temp Control
- Diagnostic Broadcast
- Unit Runtime Broadcast
- Service Info Broadcast

Battery Monitoring System

- Provides data on any batteries state of charge
- Aux battery state of health
- Aux and truck batteries voltage

Engineered Power Source System

- Deep cycle battery system
- Maintenance-free design
- UL recognized
- Pressure relief safety valve
- Meets Mil-B-8565J for hydrogen gas emissions
- Low voltage cutout

NITE Phoenix System

Description	Part No.
Nite, Standard A/C ONLY System (No Heater & Base Kit)	1000230789
NITE, Standard Combo System (with Heater & Base Kit) (Espar)	1000230787

NITE Phoenix Application Chart for Installation Kits

Make	Model	Part No.
Freightliner	Any model - Under bunk mounting	4420001
International	9000i Mfg before 06/02, 9000i Mfg after 06/02	4420002
International	ProStar, LoneStar	4420007
Kenworth	Classic Sleeper	4420001
Kenworth	T2000	4420003
Kenworth	Sofa Sleeper	4420008
Mack	Vision, CH, CL, CXU, CXN	4420001
Peterbilt	377, 379, 386, 388, with 36", 48", or 63" Sleeper	4420001
Peterbilt	387, 377, 379, 386, 388, 389 with 36", 48", or 63" Sleeper with Window, 377, 379, 386, 388, 389 with 70" Sleeper	4420004
Sterling	A-Line	4420001
Volvo	VN Classic Sleeper	4420001
Volvo	VN 77" Sleeper 780 with Work Station, VN 61" Sleeper 670 with Work Station	4420005
Western Star	4900, 4900EX, & 4900 Lomax	4420003

* For Batteries and Battery Box options, please refer to the Battery Specifications on page 31

Description	Part No.
"Phoenix Unit (No other parts, boxed)"	4475039
Drain Tube	4099082
Micro Relay	4099150
Linear Power Module	4475035
Upper Duct Louver	3275014
"Relay, 70A 12V w/Resistor"	4099086
Air Return Grill	4099106
Stealth Duct	4099116
Transition Duct	4099117
5 amp Fuse Holder	223109
60 amp Blue Fuse	4099170
20 amp Yellow Fuse	4099173
Power Harness (Aux Batteries to Unit)	4099179
100 amp Blt-On Mega Fuse Holder	4099180
10 amp Bolt-On Mega Fuse	4099188
300 amp Bi-Stable Power Relay	4475001
Internal Unit Harness Service Kit	4475002
Internal Phoenix Wire Harness	4475003
Phoenix Control Harness (Unit to Control)	4475004
Phoenix Control Harness Extension	4475005
5 amp Fuse	4475006
Male Blade Terminal	4475007
Battery Monitor System	4475008
Battery Monitor System Wire Harness	4475009
Can Bus Wire Harness	4475010
WYE DTM 3x2 Way Connector	4475011
DTM J1939 Resistor	4475012
Phoenix Upper Duct	4475013
Template Board	4475014
Wire Harness Grommet 0.62" ID	4475015
Grommet 0.56" ID x 1.25" OD	4475016
Evap Top Gasket	4475017
Bottom Gasket	4475018
Gasket 1.5x15x805	4475019
Gasket 1.5x14.5x227	4475020
NITE Phoenix Controls Kit	4475021
Condenser Shroud Assy	4475022

Description	Part No.
Filter 259x215s12.7	4475023
Fuse Cover Service Kit	4475024
Top Cover Service Kit - Condenser Side	4475025
Top Cover Service Kit - Evap Side/Blower	4475026
Unit Handle Service Kit	4475027
Temp Sensor Service Kit	4475028
Evap Cover Service Kit	4475029
Side Wrap Service Kit	4475030
Mounting Foot Service Kit	4475031
Condenser Intake Service Kit	4475032
Blower Out STD Service Kit	4475033
Blower Out ALT Service Kit	4475034
Evap Blower Service Kit	4476036
Condenser Fan Service Kit	4475037
Compressor Control Service Kit	4475038
Terra Power 300 amp Relay	4099194
Gen 3 Control Kit	4099195
Gen 2 BMS	4099196
Gen 2 BMS Harness	4099197
90-DEG 4GA Lug Terminal	4099198
DEUTSCH Conn Kit DTM-04-6P	4099199

NITE Plus System

The NITE Plus air conditioning system is an all ELECTRIC, 12 VDC system, designed to maintain sleeper compartment comfort for 8 to 10 hours without requiring your engine to idle. NITE Plus is available in A/C only or Combo configurations that provide both cooling and heating capabilities. The optional Espar air-heating system sips just 0.03 to 0.06 gallons of diesel per hour.

The NITE Plus unit requires four batteries that meet the follow specifications: AGM (Absorbed Glass Mat), Deep Cycle, Group 27 or 31. Use of any non-approved battery technology will automatically void any warranty and may impede the performance of your NITE System.

Please see www.nitesystems.com for updates.

To obtain information about any of the NITE systems go to www.nitesystem.com or call toll free 1-866-204-8570

CARB approved [# 08-643-004]



Smart Control System

- Engineered duct work for optimum airflow
- Low voltage cutout

Engineered Power Source System

- Deep cycle battery system
- Maintenance-free design
- UL recognized
- Pressure relief safety valve
- Meets Mil-B-8565J for hydrogen gas emissions
- Low voltage cutout

NITE A/C System with Smart Controller

- Cooling Capacity - 4600 BTU/h
- Voltage - 12 Volts D.C.
- Weight - 70 lbs.
- Unit Dimensions - 22.0" L x 17.0" W x 11.0" H
- Sealed hermetic system - eliminates refrigerant leaks
- Variable speed compressor - for greater efficiency
- All 12VDC components - requires no power inverter
- Brushless DC (BLDC) technology
- Patented technology

NITE Plus System

NITE Plus System

Description	Part No.
Nite, Standard A/C ONLY System (No Heater & Base Kit)	3699011
NITE, Standard Combo System (with Heater & Base Kit) (Webasto)	3699039
NITE, Standard Combo System (with Heater & Base Kit) (Espar)	3699012

NITE Plus Application Chart for Installation Kits

Make	Model	Part No.
Freightliner	Any model - Under bunk mounting	3699014
International	9000i Mfg before 06/02, 9000i Mfg after 06/02	3699015
International	ProStar, LoneStar	3699021
Kenworth	Classic Sleeper	3699014
Kenworth	T2000	3699016
Kenworth	Sofa Sleeper	3699022
Mack	Vision, CH, CL, CXU, CXN	3699014
Peterbilt	377, 379, 386, 388, with 36", 48", or 63" Sleeper	3699014
Peterbilt	387, 377, 379, 386, 388, 389 with 36", 48", or 63" Sleeper with Window, 377, 379, 386, 388, 389 with 70" Sleeper	3699017
Sterling	A-Line	3699014
Volvo	VN Classic Sleeper	3699014
Volvo	VN 77" Sleeper 780 with Work Station, VN 61" Sleeper 670 with Work Station	3699018
Western Star	4900, 4900EX, & 4900 Lomax	3699019

* For Batteries and Battery Box options, please refer to the Battery Specifications on page 31

NITE Plus Service Parts

Description	Part No.
NITE Display Stand with Unit	4100003
NITE Display Stand only (no Unit)	4100004
Knob, A/C Control - Old Style	2599050
Louver	3275014
Kit - NITE Upgraded Controls	3699007
NITE, A/C Unit Only (No Other Parts)	3699013
Fuse, MAXI 50 amp	4099075
Drain Tube	4099082
Thermostat, ELEC. - 12V Unsealed	4099084

Description	Part No.
Compressor Controller	4099085
Relay, 70A w/Resistor	4099086
Battery Separator NITE 12V, 200 amp	4099091
Recirculation Grill	4099106
Duct, Stealth	4099116
Duct, Transition	4099117
Control A/C	4099129
Knob - A/C Control - Current Style	4099132
NITTE Controller - New Switch	4099158

NITE Battery Specifications

The NITE System is powered by 4 batteries which are recharged in approximately 4 to 6 hours while the truck is running down the road.

Requirements

- Group 27 or 31
- Deep Cycle

Performance

- Voltage - 6 VDC - 6 volt batteries must have a minimum of 110 amp hour rating
- Voltage - 12 VDC - 12 volt batteries must have a minimum of 105 amp hour rating
- Use of any non-approved battery technology will automatically void any warranty and may impede the performance of the NITE system

NITE Power System (AGM Batteries)

- Capacity - 440 amp hours
- Battery Life - 2+ years
- Operates - 8-10 hours
- Recharge Time - 4-6 hours
- Weight - 300 lbs.
- Dimensions - 12.93" L x 6.75" W x 9.34" H
- Alternator - add an additional 30+ amps

NITE System Add-On Options

Description	Part No.
Battery, 13.42" L x 6.80" D x 9.21" H (Trojan)	3699032
Battery Box Options:	
Battery Box Kit, Quantity of 2, each box holds 2 batteries, Dimensions: 20" L x 14.5" D x 12" H	3699010
Vertical Clamp on Aluminum Battery Box, holds 4 batteries, Dimensions: 16.45" L x 20.25" D x 24.2" H	3699025
Z Brackets Kit, Quantity of 2, used to mount steel battery boxes away from structure on frame rail	4499010
Lid Deck for Battery Box 27"	3699034
Lid Deck for Battery Box 28"	3699035
Between the Rail Aluminum Battery Box, holds 4 batteries	3699033

NITE Day Cab System

Technical Specifications

- Performance - Cooling, 7,200 BTU/h (2.11 kW)
- Air Flow - 180 CFM (323 CMH)
- Current Draw - 25-55 amps @ 12 Volts D.C. (636 watts)
- System requires refrigerant charge

Features

- Split System: Condenser unit outside, evaporator unit inside cab
- 3 Fan Speeds
- Virtually Maintenance Free
- Quiet Operation
- Easy to Clean Interior Filter
- Optional Voltages, available on request

Construction

- Shell Constructed with Durable Steel
- Electrified Unit, runs on auxillary AGM / deep cycle batteries (minimum 12v required)
- R134a Refrigerant

Weights and Dimensions

	Interior Unit	Exterior Unit
• Weight	52 lbs 23.6 kg	25 lbs 11.3 kg
• Length	10.9 in 276.4 mm	18.9 in 480.8 mm
• Depth	10.9 in 276.4 mm	6.6 in 167.8 mm
• Height	27.3 in 692.3 mm	13.4 in 339.1 mm

Warranty

- 1 year limited warranty on parts and labor

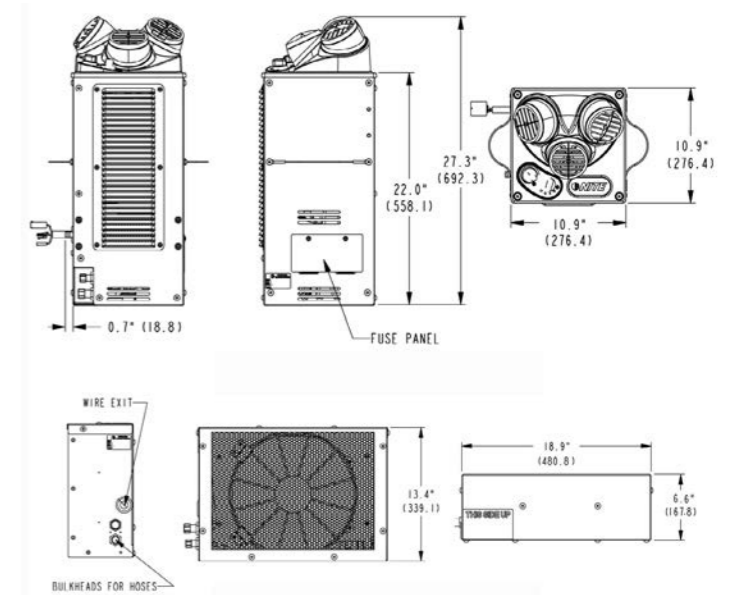

NITE Day Cab System

Description	Part No.
NITE, Electrified Day Cab System Standard Kit, includes external kit, internal kit, and Day Cab power kit	3699029
NITE, Electrified Day Cab Installation Kit, includes all hardware for both the external and internal kits	3699030
Battery Box Kit, holds up to 2 batteries, steel construction	4099131
Battery, Quantity 1 (Trojan, Group 31, 12V)	3699031
NITE Electrified DayCab Combo (Webasto)	3699038
NITE Electrified DayCab Combo (Espar)	3699037

Lined area for handwritten notes.

Index

223109	3	4099180	3
2599050	5	4099188	3
3275014	3, 5	4099194	3
3699007	5	4099195	3
3699010	6	4099196	3
3699011	5	4099197	3
3699012	5	4099198	3
3699013	5	4099199	3
3699014	5	4100003	5
3699015	5	4100004	5
3699016	5	4420001	2
3699017	5	4420002	2
3699018	5	4420003	2
3699019	5	4420004	2
3699021	5	4420005	2
3699022	5	4420007	2
3699025	6	4420008	2
3699029	7	4475001	3
3699030	7	4475002	3
3699031	7	4475003	3
3699032	6	4475004	3
3699033	6	4475005	3
3699034	6	4475006	3
3699035	6	4475007	3
3699037	7	4475008	3
3699038	7	4475009	3
3699039	5	4475010	3
4099075	5	4475011	3
4099082	3, 5	4475012	3
4099084	5	4475013	3
4099085	5	4475014	3
4099086	3, 5	4475015	3
4099091	5	4475016	3
4099106	3, 5	4475017	3
4099116	3, 5	4475018	3
4099117	3, 5	4475019	3
4099129	5	4475020	3
4099131	7	4475021	3
4099132	5	4475022	3
4099150	3	4475023	3
4099158	5	4475024	3
4099170	3	4475025	3
4099173	3	4475026	3
4099179	3	4475027	3

Index

4475028.....	3
4475029.....	3
4475030.....	3
4475031.....	3
4475032.....	3
4475033.....	3
4475034.....	3
4475035.....	3
4475037.....	3
4475038.....	3
4475039.....	3
4476036.....	3
4499010.....	6
1000230787.....	2
1000230789.....	2

